

**ELECTRIC GUITAR, CELLO, PERCUSSION
(LARGE SUSPENDED CYMBAL, SMALL TAM TAM,
MEDIUM TAM TAM, LARGE BASS DRUM), PIANO**

DURATION : 12 MINUTES

**COMMISSIONED BY MAERZMUSIK 2003/
BERLINER FESTSPIELE**

For John White

JOHN WHITE IN BERLIN

♩ = 60 Very Soft and Still

Laurence Crane

Electric Guitar

Cello

Percussion

Piano

Ped. →

⌘ * Place the e bows on the relevant strings before the piece starts. Depress the sustaining pedal to activate the chord. It may take a bit of time for all 4 notes to speak properly. The start of bar 1 is the moment that the player depresses the pedal, not the moment that all 4 notes sound for the first time. The e bows remain in place for the duration of the work.

9

Perc.

Pno

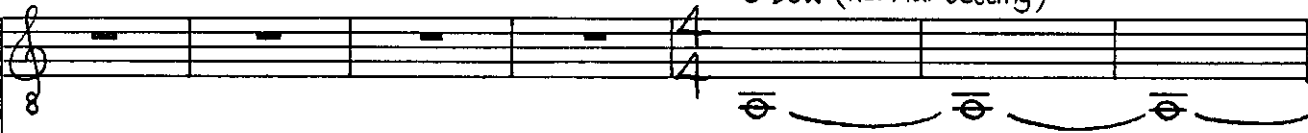

(Ped.) →

17

E.Gtr  * e bow (normal setting)

Vc.  **

Perc.  (Sm. T-T) **LARGE SUSPENDED CYMBAL** soft sticks



Pno   (Ped.) →

24

E.Gtr  8

Vc. 

Perc. 

Pno   (Ped.) →

* The note should speak on the first beat of bar 21. Some preparation may be necessary.
 ** All cello harmonics notated at sounding pitch. Method of production is at the discretion of the performer.

30

Musical score for measures 30-35. It consists of three staves: a treble clef staff with a series of tied notes, a bass clef staff with a rhythmic pattern of eighth notes, and a percussion staff with a wavy line and tied notes.

||

36

Musical score for measures 36-41. It consists of five staves: a treble clef staff with rests and measure numbers (3, 2, 3, 4), a bass clef staff with notes and measure numbers (3, 2, 3, 4), a percussion staff with a wavy line and tied notes, and a grand staff (treble and bass clefs) with chords and measure numbers (3, 2, 3, 4). Annotations include "no vibrato" and "SMALL TAM-TAM".

(Ped.) →

no vibrato

SMALL TAM-TAM

(Ped.) →

U.C. →

4

42

Vc.

(Sm. T-T)

Perc.

Pno

(Ped.) →
(U.C.) →

||

48

(Ped.) →
(U.C.) →

Preview File Only

E.Gtr *e bow*

Vc.

Perc. **LARGE BASS DRUM** soft sticks

Pno

60 (Ped. x U.C.)

E.Gtr

Vc.

Perc.

E.Gtr

Vc.

Perc. **LARGE SUSPENDED CYMBAL**

Pno *4 e bows*

c.5" c.5" c.10" c.5" * c.5" c.10" c.10"

* Percussionist moves to Large Suspended Cymbal when Piano chord has started to sound and Electric Guitar has faded out.

Ped. →

Preview File Only

6

72 (♩ = 60)

e bow, very smooth to bar 108

E.Gtr

Perc.

Pno

LARGE SUSPENDED CYMBAL

pluck strings with fingernail

(Ped.) →

78

(Ped.) →

85

(Ped.) →

92

MEDIUM TAM-TAM soft sticks

(Ped.) →

Detailed description: This system contains five staves. The top staff is a treble clef with a 4/4 time signature, featuring a melodic line with quarter notes and rests, and a fermata over the final measure. The second staff is a bass clef with a 4/4 time signature, mirroring the top staff's rhythm. The third and fourth staves are a grand staff (treble and bass clefs) with a 4/4 time signature, showing a piano accompaniment with chords and a wavy line representing a tam-tam. The bottom staff is a bass clef with a 4/4 time signature, showing a piano accompaniment with chords and a wavy line representing a tam-tam. A box labeled 'MEDIUM TAM-TAM soft sticks' is placed above the wavy lines. A '(Ped.) →' marking is below the bottom staff.

97

(Ped.) →

Detailed description: This system contains five staves. The top staff is a treble clef with a 3/4 time signature, featuring a melodic line with quarter notes and rests. The second staff is a bass clef with a 3/4 time signature, mirroring the top staff's rhythm. The third and fourth staves are a grand staff (treble and bass clefs) with a 3/4 time signature, showing a piano accompaniment with chords and a wavy line representing a tam-tam. The bottom staff is a bass clef with a 3/4 time signature, showing a piano accompaniment with chords and a wavy line representing a tam-tam. A '(Ped.) →' marking is below the bottom staff.

102

(Ped.) →

Detailed description: This system contains five staves. The top staff is a treble clef with a 5/4 time signature, featuring a melodic line with quarter notes and rests. The second staff is a bass clef with a 5/4 time signature, mirroring the top staff's rhythm. The third and fourth staves are a grand staff (treble and bass clefs) with a 5/4 time signature, showing a piano accompaniment with chords and a wavy line representing a tam-tam. The bottom staff is a bass clef with a 5/4 time signature, showing a piano accompaniment with chords and a wavy line representing a tam-tam. A '(Ped.) →' marking is below the bottom staff.

108

E.Gtr



Vc.



SMALL TAM-TAM

Perc.



Pno



Pno



(Ped.) →
U.C. →



113

Vc.



Perc.



Pno



Pno

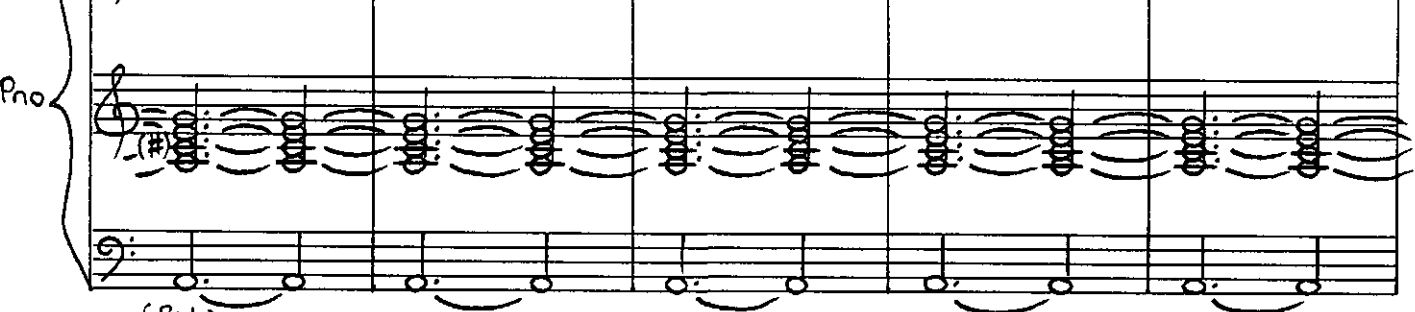

(Ped.) →
(U.c.) →

118

E.Gtr

8

e bow

Vc.

Perc.

LARGE BASS DRUM

Pno

(Ped. + U.C.)

124

E.Gtr

8

Vc.

no vibrato

Perc.

132

8

Preview File Only

140

E.Gtr. *c5"* *c5"* *sim. sempre*

Vc. *c10"* **LARGE SUSPENDED CYMBAL** *c5"*

Perc. *(Lge B.D.) c5"* *c10"*

Pno *4 e bows c10"* *c10"*

Ped. →

== *

* Percussionist moves to Large Suspended Cymbal when Piano chord has started to sound and Electric Guitar has faded out.

144

(Ped.) →

149

E.Gtr

Vc.

Perc.

Pno

(Ped.) →

SMALL TAM-TAM



154

(Ped.) →

159

E. Gtr

Vc.

(Sm. T-T)

Perc.

Pno

(Ped.) →

Preview File Only

165

Pno

(Ped.) →

171

E.Gtr

Vc.

Perc. **MEDIUM TAM-TAM**

Pno

(Ped.) →



176

E.Gtr

Vc.

Perc.

Pno

(Ped.) →

181

E.Gtr

Vc.

Perc.

Pno

(Med. T-T)

LARGE SUSPENDED CYMBAL

(Ped.) →

Preview File Only

186

(Ped.) →

192

15

(Ped.) →

197

(Ped.) →

Preview File Only